

REV	DATE	ECO	DESCRIPTION	BY	CK	APP
-	4-15-99	N/A	INITIAL RELEASE	LDB	N/A	N/A

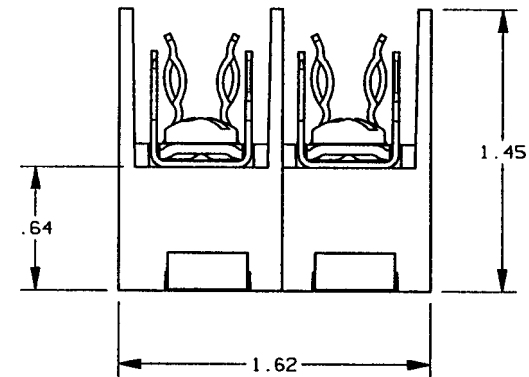
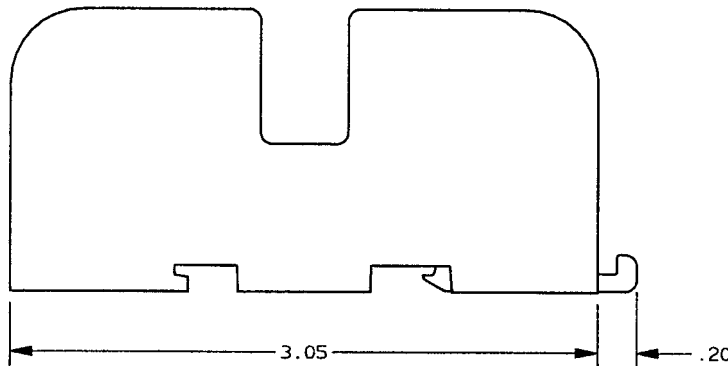
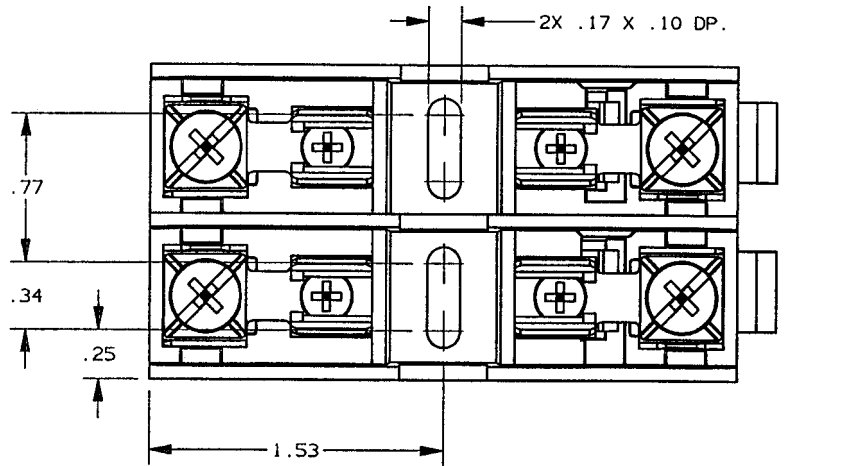

NOTES:

1. MATERIAL COMPOSITION AND RATING:
BASE - THERMOPLASTIC 125°C RTI
2. ALL TOLERANCES ±.010 UNLESS OTHERWISE NOTED

P/N	CONN TYPE	RMS SYM RATING	TORQUE (IN-LBS)	WIRE		U/L		CSA
				°C	TYPE	FILE NO.	GUIDE NO.	REPORT NO.
40222G	PRESSURE	100K	20	60/75	CU ONLY	E52283	IZLT	LR32169



GOULD

374 MERRIMAC STREET
NEWBURYPORT, MA 01950

PRODUCT MANAGER

DESIGN ENGINEER

SIGN: *Nickal Zili*
DATE: 5-10-99

SIGN: *Elizabeth T. Ryan*
DATE: 5/10/99

FUSE BLOCK, 600V-20A, 2 POLE
CLASS G

OUTLINE DIMENSIONS
NOT TO BE USED FOR PRODUCTION

700462